

Dell Networking Optics and Cables Connectivity Guide

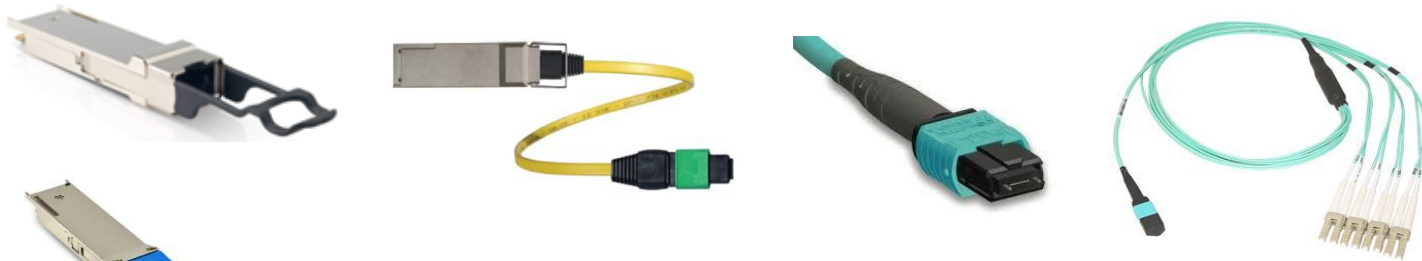

1 Gigabit Ethernet (1GbE)



10 Gigabit Ethernet (10GbE)



40 Gigabit Ethernet (40GbE)



100 Gigabit Ethernet (100GbE)



Fibre Channel

Networking I/O Connectivity Options

March 2016

Saleem Muhammad, Product Management

Contents

Optics and Cables Selection by Use Case

- Key factors influencing the decision 3
- Server to switch connectivity 4
- Storage to switch connectivity 5
- Switch to switch connectivity 6
- Optics and cables positioning 7



Quick Reference Guide

- Optics connectivity 9
- Cables connectivity 12



Frequently Asked Questions

- Types of cables and the concept of lanes 15



Deployment and Technical Guides 17

Optics and cables selection by use case

Key factors* influencing the decision

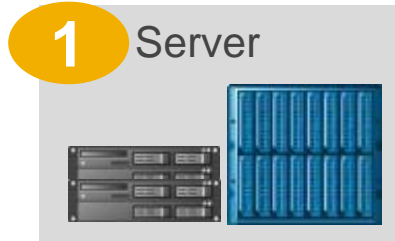

1 Server



Bandwidth

- Application load requirements typically drive the 1GbE, 10GbE, 25GbE, 40GbE, or 100GbE decision. Type of traffic can also be a deciding factor, e.g. DCB requires 10GbE or higher.

Cost

- Servers claim the highest share of devices deployed in any data center. Choosing a lower cost connectivity option results in a much lower initial deployment cost.

Power

- In any high density server deployment, a connectivity option which consumes lower power results in much lower OpEx.

Distance

- Servers are typically connected to a switch over a very short distance i.e. typically within the same rack or, in some cases, within the same row.

Distance and flexibility

- Servers are typically connected to a switch over a very short distance, typically within the same rack or row. A SFP+ switch with DAC and optic connect option will offer a lower latency and more flexible solution than 10GBaseT. Customers that prefer to make their own copper cables due to variable distance requirements will be limited to 1000BaseT and 10GBaseT options.



Bandwidth

- On server facing ports, servers typically dictate the per port bandwidth requirement. However, per port bandwidth requirement for the network facing (switch-to-switch) ports depends on multiple factors including amount of traffic generated by the servers, oversubscription ratios, fiber limitations, etc.

Distance

- An inter-switch or switch to router connection could range from a few inches to tens of kilometers. Generally, the price of optics increases as the distance increases.

Latency

- The network topology and application traffic profile (East-west, HPC, computer clusters, etc.) and influence the minimum latency that can be tolerated in the network.

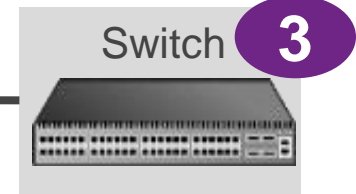

Reliability

- Typical storage traffic is very sensitive to loss. Even a minor loss of traffic may result in major impact on application performance.

Qualification

- Storage vendor qualification or recommendation plays an important role in this decision due to reasons such as customer support, peace of mind, etc.

Latency

- Any time spent in transition is time taken away from data processing. Reducing transition time results in much faster application performance. The result may have a direct impact on customers' bottom line e.g. faster processing of online orders.

Optics and cables selection by use case

Server to switch connectivity

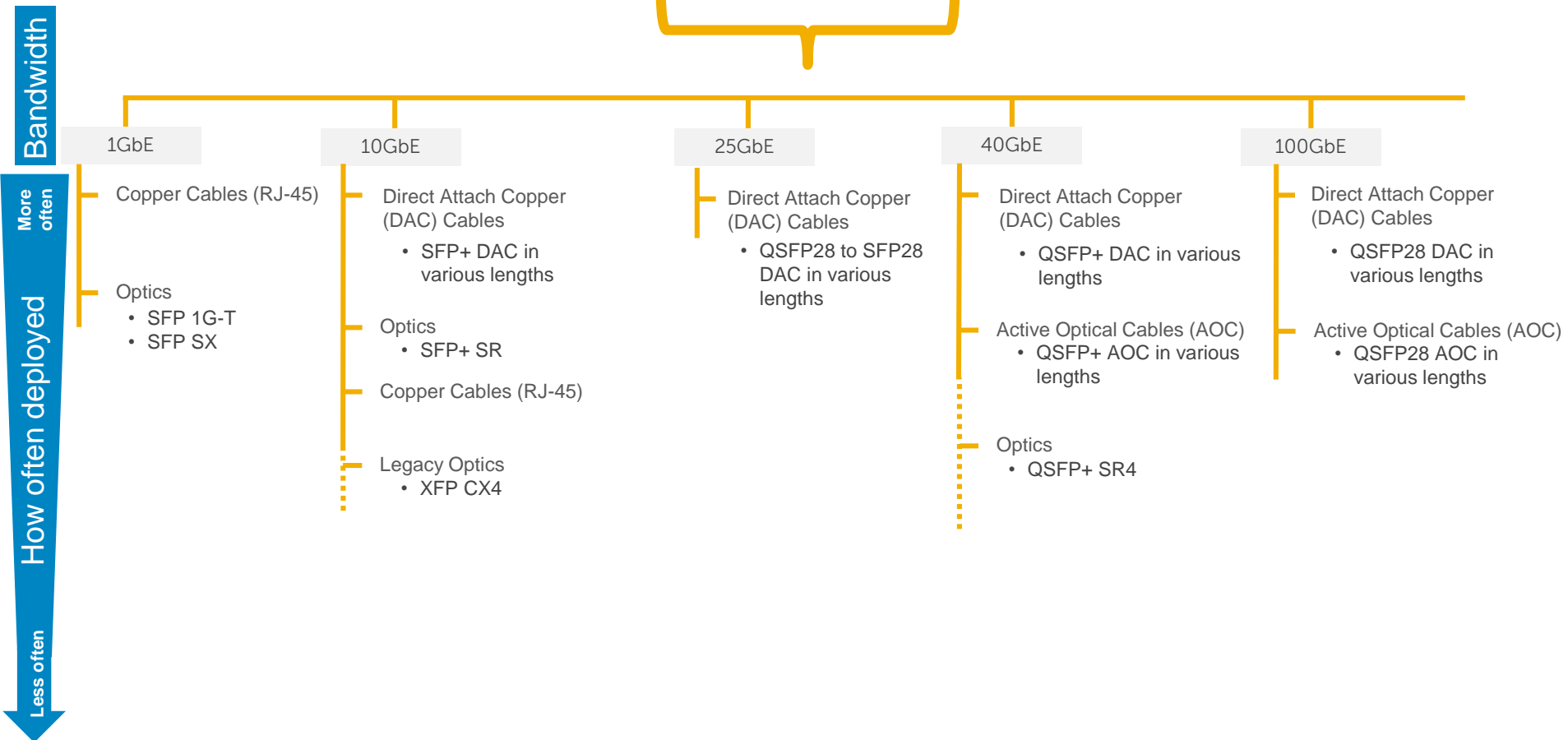

Optics and cables selection by use case

Storage to switch connectivity

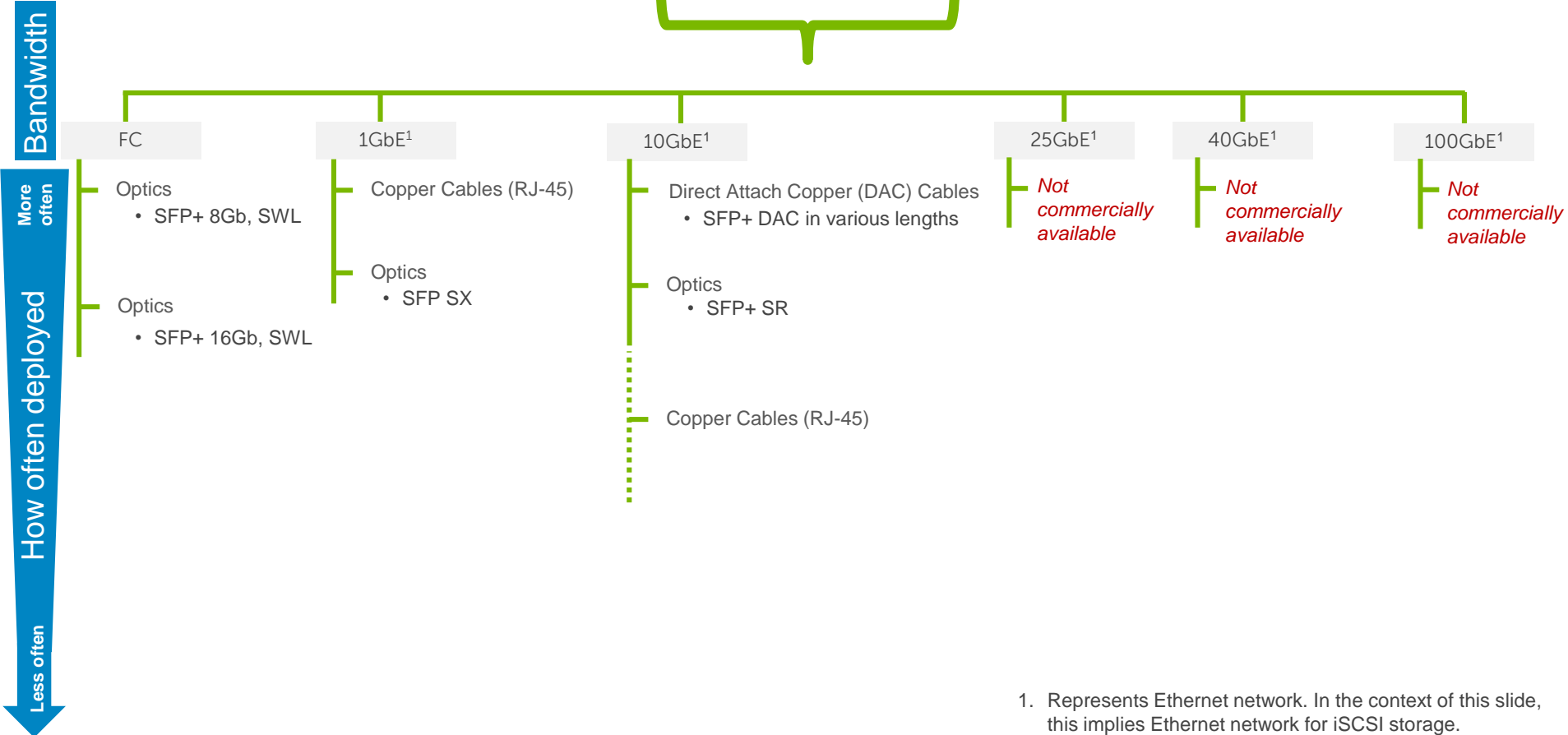

1. Represents Ethernet network. In the context of this slide, this implies Ethernet network for iSCSI storage.



Optics and cables selection by use case

Switch to switch connectivity

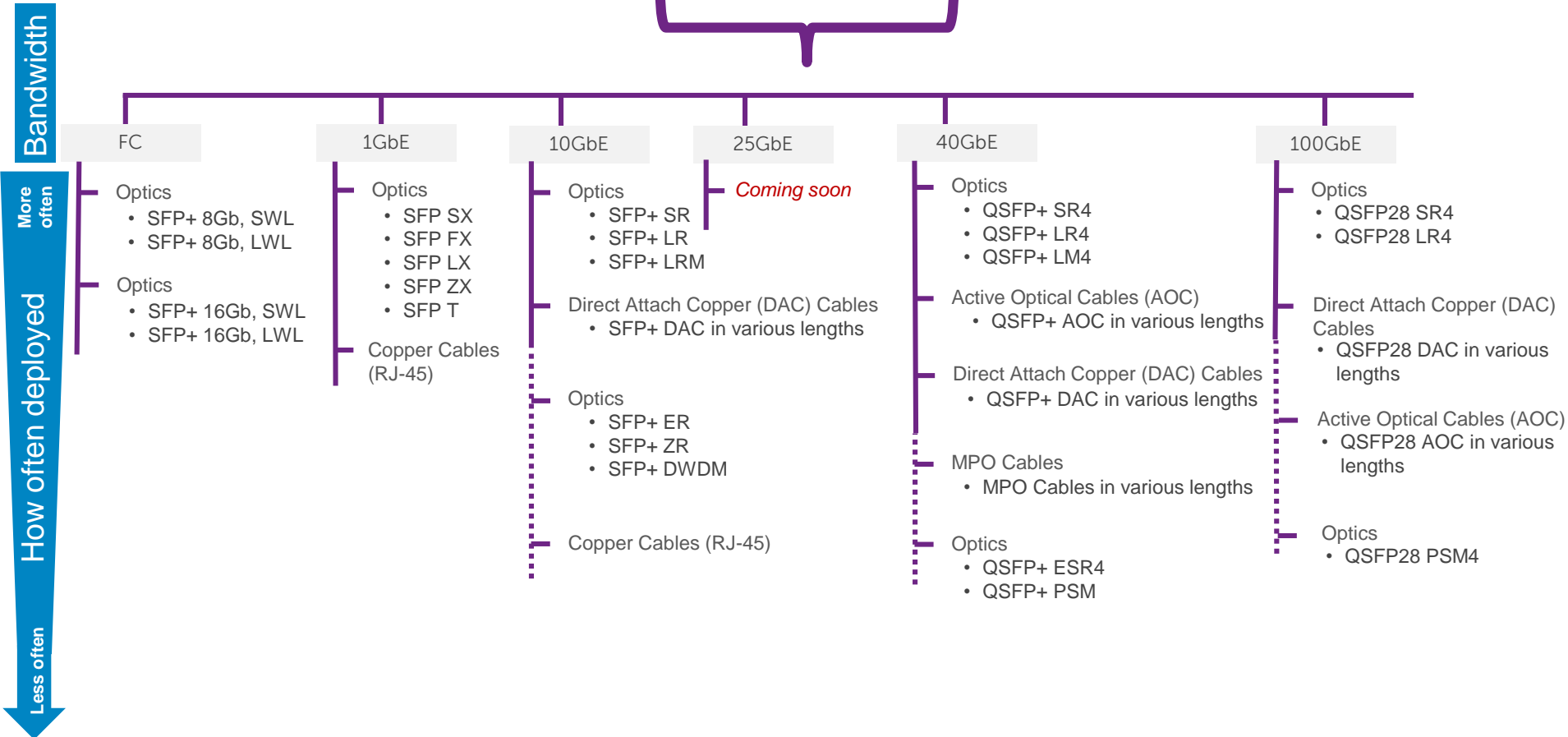

Optics and Cables Positioning

Optics

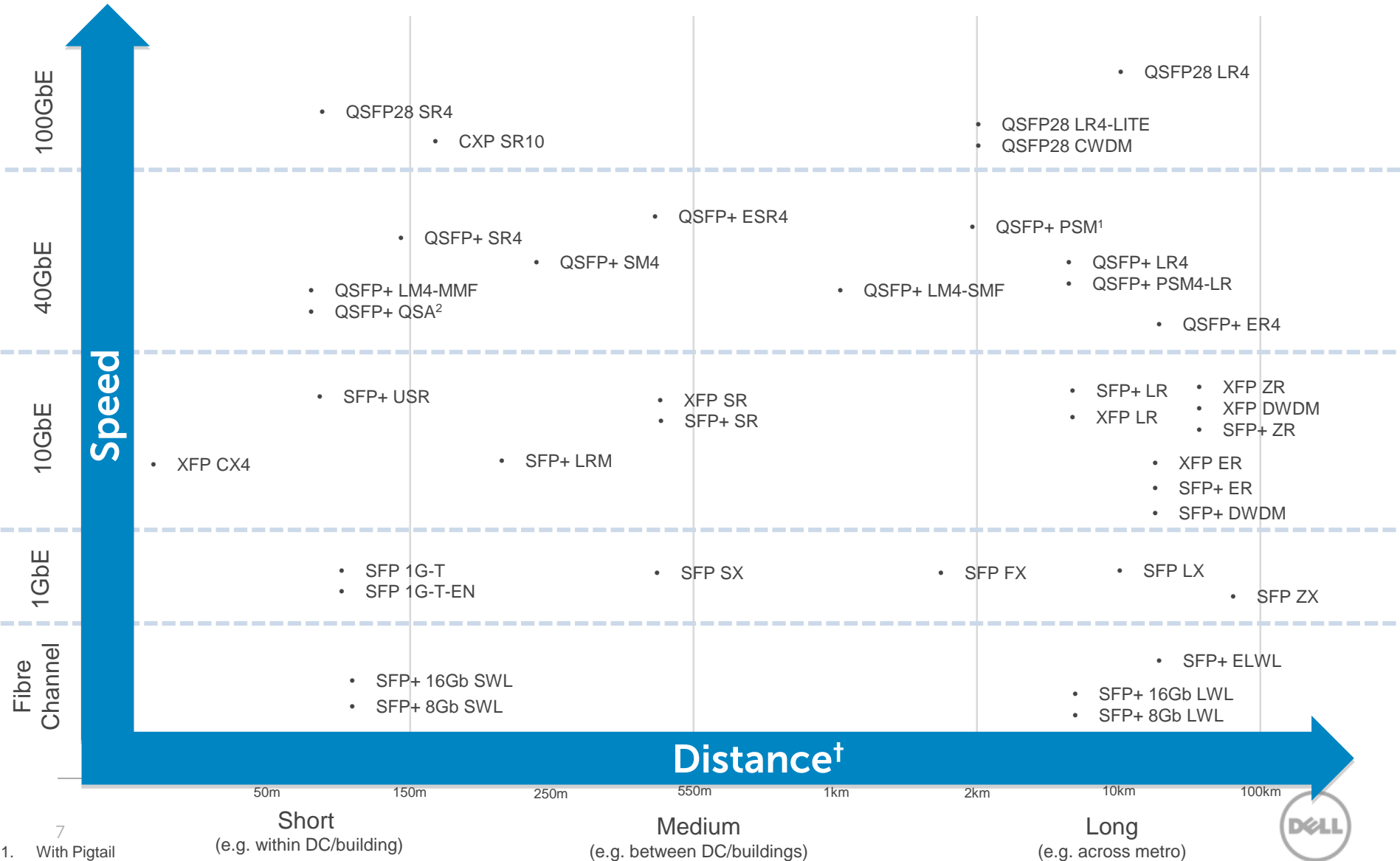

1. With Pigtail
 2. Distance varies based on the customers selection of optics † Based on maximum supported distance on best grade fiber. See the Quick Reference Guide for additional distances using lower grade fiber

Optics support on Dell Networking / ON

Dell and 3rd party OS

	Dell Networking			Big Switch		Cumulus	IP Infusion	Pluribus
	OS 6	OS 9	OS 10	BCF	BMF	CumulusOS	OcNOS	NetVisor
<u>Dell Optics</u>								
Supported	Yes			Yes ¹		Yes ¹	Yes ¹	Yes ¹
Blocked	No			No		No	No	No
Support provided by	Dell			Big Switch / Dell		Cumulus / Dell	IP Infusion / Dell	Pluribus / Dell
<u>3rd Party Optics</u>								
Supported	No			Yes ²		Yes ²	Yes ²	Yes ²
Blocked	(Note 2)			No		No	No	No
Support provided by	Customer ³			Partner		Partner	Partner	Partner

Notes

1. Not all Dell optics may be supported. Please check with your sales rep for more specific guidance.
2. Please check with your sales rep for more specific guidance.
3. Vendor does not offer any support for this solution.



Quick Reference Guide







Optics / Transceivers Connectivity

Quick Reference Guide

100MbE and 1GbE

	Models	IEEE Standard	MSA	Receptacle	Power	Wavelength	Distance	Fiber	Mode
	SFP-100M-FX	802.3u	SFP	Duplex LC	≤1.5W	1310nm	2km (OM1, OM2)	SMF	1→1
	SFP-1G-T	802.3z	SFP	RJ-45	≤1.5W	NA	100m	Cat5/6	1→1
	SFP-1G-T-EN	802.3z	SFP	RJ-45	≤1.5W	NA	100m	Cat5/6	1→1
	SFP-1G-SX	802.3z	SFP	Duplex LC	≤1.5W	850nm	200m (FDDI grade)	MMF	1→1
							275m (OM1)		
							550m (OM2, OM3, OM4)		
SFP-1G-LX	802.3z	SFP	Duplex LC	≤1.5W	1310nm	10km	SMF	1→1	
						550m (FDDI grade, OM1, OM2)	MMF ⁸		
SFP-1G-ZX	802.3z	SFP	Duplex LC	≤1.5W	1550nm	80km	SMF	1→1	
	SFP-10G-SR SFP-10G-SR-12	802.3ae	SFP+	Duplex LC	≤1.5W	850nm	26m (FDDI grade)	MMF	1→1
							33m (OM1)		
							82m (OM2)		
							300m (OM3)		
							400m (OM4)		
	SFP-10G-USR	802.3ae	SFP+	Duplex LC	≤1.5W	850nm	100m (OM3)	MMF	1→1
							150m (OM4)	MMF	1→1
	SFP-10G-LRM	802.3ae	SFP+	Duplex LC	≤1.5W	1310nm	220m (FDDI grade, OM1, OM2, OM3, OM4)	MMF	1→1
							10km	SMF	
	SFP-10G-LR	802.3ae	SFP+	Duplex LC	≤1.5W	1310nm	10km	SMF	1→1
40km							SMF		
40km							SMF		
80km							SMF		
SFP-10G-ER ⁵ SFP-10G-W17 through SFP-10G-W61 ² SFP-10G-T-DWDM ⁹ SFP-10G-ZR ⁵	802.3ae	SFP+	Duplex LC	≤1.5W	1550nm	40km	SMF	1→1	
	N/A	SFP+	Duplex LC	≤1.5W	C-Band, 100GHz	40km	SMF	1→1	
	802.3-2012 clause 52	SFP+	Duplex LC	≤1.65W	C-Band 50GHz	80km	SMF	1→1	
SFP-10G-ZR ⁵	SFF-8431 SFF-8432	SFP+	Duplex LC	≤1.5W	1550nm	80km	SMF	1→1	



Optics / Transceivers Connectivity







Quick Reference Guide

	Models	IEEE Standard	MSA	Receptacle	Power	Wavelength	Distance	Fiber	Mode
10GbE	 XFP-10G-SR ⁴	802.3ae	XFP	Duplex LC	≤1.5W	850nm	26m (FDDI grade)	MMF	1→1
							33m (OM1)		
							82m (OM2)		
							300m (OM3)		
							400m (OM4)		
	 XFP-10G-LR ⁴ XFP-10G-ER ^{4, 5} XFP-10G-ZR ^{4, 5} XFP-10G-W21 through XFP-10G-W60 ^{4, 2}	802.3ae	XFP	Duplex LC	≤1.5W	1310nm	10km	SMF	1→1
		802.3ae	XFP	Duplex LC	≤1.5W	1550nm	40km	SMF	1→1
802.3ae		XFP	Duplex LC	≤1.5W	1550nm	80km	SMF	1→1	
N/A		XFP	Duplex LC	≤1.5W	C-Band, 100GHz	80km	SMF	1→1	
 XFP-10G-CX ⁴	802.3ak	XFP	Duplex LC	≤1.5W	850nm	15m	MMF	1→1	
40GbE	 QSA-QSFP-SFP ⁺	802.3ba	NA	NA	≤1.5W	Varies	Varies	Varies	1→1
	 QSFP-40G-LM ⁴	802.3ba	QSFP+	Duplex LC	≤3.5W	1310nm	140m (OM3)	MMF	1→1
							160m (OM4)		
							1km	SMF	1→1
	 QSFP-40G-SR ⁴ QSFP-40G-ESR ⁴	802.3ba	QSFP+	MPO	≤1.5W	850nm	100m (OM3)	MMF	1→1, 1→4
							150m (OM4)		
		802.3ba	QSFP+	MPO	≤1.5W	850nm	300m (OM3)	MMF	1→1, 1→4
							400m (OM4)		
	 QSFP-40G-PSM-1M QSFP-40G-PSM-5M QSFP-40G-PSM-15M	802.3ba	QSFP+	MPO Pig-tail ¹	≤1.5W	1490nm	2km	SMF	1→1
		802.3ba	QSFP+	MPO Pig-tail ¹	≤1.5W	1490nm	2km	SMF	1→1
		802.3ba	QSFP+	MPO Pig-tail ¹	≤1.5W	1490nm	2km	SMF	1→1
 QSFP-40G-PSM ⁴ -LR	802.3ba	QSFP+	MPO	≤3.5W	1310nm	10km	SMF	1→4	
 QSFP-40G-LR ⁴	802.3ba	QSFP+	Duplex LC	≤3.5W	1310nm	10km	SMF	1→1	
 QSFP-40G-SM ⁴ ⁹	802.3ba	QSFP+	Duplex LC	≤1.5W	850nm	200m (OM3), 250m (OM4)	MMF	1→1	



Optics / Transceivers Connectivity

Quick Reference Guide

	Models	IEEE Standard	MSA	Receptacle	Power	Wavelength	Distance	Fiber	Mode	
		QSFP-40G-ER4⁹	802.3ba	QSFP+	Duplex LC	≤3.5W	1310nm	40km	SMF	1→1
100GbE		QSFP28-100G-SR4	802.3bm	QSFP28	MPO	≤3.5W	850nm	70m (OM3) 100m (OM4)	MMF	1→1
		QSFP28-100G-LR4	802.3ba	QSFP28	Duplex LC	≤4.5W	1310nm	10km	SMF	1→1
		QSFP28-100G-LR4-LITE	802.3ba	QSFP28	Duplex LC	≤4.0W	1310nm	2km	SMF	1→1
		QSFP28-100G-CWDM⁹	(Note 4)	QSFP28	Duplex LC	≤3.5W	1310nm	2km	SMF	1→1
		CXP-100G-SR10⁹	802.3ba	CXP	MPO	≤3.5W	850nm	100m (OM3) 150m (OM4)	MMF	1→1
		SFP-8GFC-LWL	NA	SFP+	Duplex LC	≤1.5W	1260nm – 1360nm	10km	SMF	1→1
		SFP-8GFC-ELWL	NA	SFP+	Duplex LC	≤1.5W	1260nm – 1360nm	25km	SMF	1→1
		SFP-16GFC-SWL	NA	SFP+	Duplex LC	0.8W	770nm – 860nm	125m (OM4)	MMF	1→1
		SFP-16GFC-LWL	NA	SFP+	Duplex LC	≤1.5W	1295nm – 1325nm	10km	SMF	1→1



Cables Connectivity







Quick Reference Guide

		Models	IEEE Standard	MSA	Power	Bend Radius	Distance	Cable	Mode
10GbE		DAC-SFP-10G-0.5M	802.3ae (SFI)	SFP+	Passive	35mm	0.5m	Copper	1→1
		DAC-SFP-10G-1M	802.3ae (SFI)	SFP+	Passive	35mm	1m	Copper	1→1
		DAC-SFP-10G-2M ⁹	802.3ae (SFI)	SFP+	Passive	35mm	2m	Copper	1→1
		DAC-SFP-10G-3M	802.3ae (SFI)	SFP+	Passive	35mm	3m	Copper	1→1
		DAC-SFP-10G-5M	802.3ae (SFI)	SFP+	Passive	45mm	5m	Copper	1→1
		DAC-SFP-10G-7M	802.3ae (SFI)	SFP+	Passive	45mm	7m	Copper	1→1
		AOC-SFP-10G-2M ⁹	802.3ae (SFI)	SFP+	≤1.5W	30mm	2m	MMF	1→1
		AOC-SFP-10G-3M ⁹	802.3ae (SFI)	SFP+	≤1.5W	30mm	3m	MMF	1→1
		AOC-SFP-10G-5M ⁹	802.3ae (SFI)	SFP+	≤1.5W	30mm	5m	MMF	1→1
		AOC-SFP-10G-7M ⁹	802.3ae (SFI)	SFP+	≤1.5W	30mm	7m	MMF	1→1
		AOC-SFP-10G-10M ⁹	802.3ae (SFI)	SFP+	≤1.5W	30mm	10m	MMF	1→1
		AOC-SFP-10G-15M	802.3ae (SFI)	SFP+	≤1.5W	30mm	15m	MMF	1→1
		AOC-SFP-10G-20M ⁹	802.3ae (SFI)	SFP+	≤1.5W	30mm	20m	MMF	1→1
40GbE		DAC-QSFP-40G-0.5M	802.3ba (CR4)	QSFP+	Passive	50mm	0.5m	Copper	1→1
		DAC-QSFP-40G-1M	802.3ba (CR4)	QSFP+	Passive	50mm	1m	Copper	1→1
		DAC-QSFP-40G-2M ⁹	802.3ba (CR4)	QSFP+	Passive	50mm	2m	Copper	1→1
		DAC-QSFP-40G-3M	802.3ba (CR4)	QSFP+	Passive	50mm	3m	Copper	1→1
		DAC-QSFP-40G-5M	802.3ba (CR4)	QSFP+	Passive	60mm	5m	Copper	1→1
		DAC-QSFP-40G-7M	802.3ba (CR4)	QSFP+	Passive	66mm	7m	Copper	1→1
		AOC-QSFP-40G-10M	802.3ba (XLPP1)	QSFP+	≤1.5W		10m	MMF	1→1
		AOC-QSFP-40G-50M	802.3ba (XLPP1)	QSFP+	≤1.5W		50m	MMF	1→1
		DAC-QSFP-4SFP-10G-0.5M	802.3ae (SFI)	QSFP+	Passive	70mm/35mm	0.5m	Copper	1→4
		DAC-QSFP-4SFP-10G-1M	802.3ae (SFI)	QSFP+	Passive	70mm/35mm	1m	Copper	1→4
		DAC-QSFP-4SFP-10G-2M ⁹	802.3ae (SFI)	QSFP+	Passive	70mm/35mm	2m	Copper	1→4
		DAC-QSFP-4SFP-10G-3M	802.3ae (SFI)	QSFP+	Passive	70mm/35mm	3m	Copper	1→4
		DAC-QSFP-4SFP-10G-5M	802.3ae (SFI)	QSFP+	Passive	80mm/40mm	5m	Copper	1→4



Cables Connectivity



Quick Reference Guide

		Models	IEEE Standard	MSA	Power	Bend Radius	Distance	Cable	Mode
40GbE		DAC-QSFP-4SFP-10G-7M	802.3ae (SFI)	QSFP+	Passive	90mm/45mm	7m	Copper	1→4
		DAC-QSFP-4SFP-10G-10M	802.3ae (SFI)	QSFP+	Passive	90mm/45mm	10m	Copper	1→4
		DAC-QSFP-4SFP-10G-30M	802.3ae (SFI)	QSFP+	Passive	90mm/45mm	30m	Copper	1→4
		DAC-QSFP-4RJ45-1G-1M	802.3ae (SFI)	QSFP+	Passive		1m	Cat5/6	1→4
		AOC-QSFP-4SFP-10G-10M ⁹	802.3ae (SFI)	QSFP+	≤1.5W		10m	MMF	1→4
		AOC-QSFP-4SFP-10G-30M ⁹	802.3ae (SFI)	QSFP+	≤1.5W		30m	MMF	1→4
100GbE		DAC-QSFP28-100G-1M	802.3bj (CR4)	QSFP28	Passive		1m	Copper	1→1
		DAC-QSFP28-100G-2M	802.3bj (CR4)	QSFP28	Passive		2m	Copper	1→1
		DAC-QSFP28-100G-3M	802.3bj (CR4)	QSFP28	Passive		3m	Copper	1→1
		DAC-QSFP28-100G-5M	802.3bj (CR4)	QSFP28	Passive		5m	Copper	1→1
		DAC-Q28-4SFP28-25G-1M	25GE Consortium	QSFP28	Passive		1m	Copper	1→4
		DAC-QSFP28-4SFP28-25G-2M	25GE Consortium	QSFP28	Passive		2m	Copper	1→4
		DAC-QSFP28-4SFP28-25G-3M	25GE Consortium	QSFP28	Passive		3m	Copper	1→4
		AOC-QSFP28-100G-7M	802.3bm (CAUI4)	QSFP28	≤3.5W		7m	MMF	1→1
		AOC-QSFP28-100G-10M	802.3bm (CAUI4)	QSFP28	≤3.5W		10m	MMF	1→1
		AOC-QSFP28-100G-30M	802.3bm (CAUI4)	QSFP28	≤3.5W		30m	MMF	1→1
		AOC-QSFP28-100G-50M	802.3bm (CAUI4)	QSFP28	≤3.5W		50m	MMF	1→1
		CBL-MTP24-OM4-5M	NA	CXP ¹⁰	NA		5m	MMF	1→1



Cables Connectivity

Quick Reference Guide

		Models	IEEE Standard	MSA	Power	Bend Radius	Distance	Cable	Mode
Variable Speed		CBL-MTP12-OM4-1M	NA	QSFP+ ⁷	NA		1m	MMF	1→1
		CBL-MTP12-OM4-3M	NA	QSFP+ ⁷	NA		3m	MMF	1→1
		CBL-MTP12-OM4-5M	NA	QSFP+ ⁷	NA		5m	MMF	1→1
		CBL-MTP12-OM4-7M	NA	QSFP+ ⁷	NA		7m	MMF	1→1
		CBL-MTP12-OM4-10M	NA	QSFP+ ⁷	NA		10m	MMF	1→1
		CBL-MTP12-OM4-25M	NA	QSFP+ ⁷	NA		25m	MMF	1→1
		CBL-MTP12-OM4-50M	NA	QSFP+ ⁷	NA		50m	MMF	1→1
		CBL-MTP12-OM4-75M	NA	QSFP+ ⁷	NA		75m	MMF	1→1
		CBL-MTP12-OM4-100M	NA	QSFP+ ⁷	NA		100m	MMF	1→1
		CBL-MTP12-4LC-OM4-1M	NA	QSFP+ ⁶	NA		1m	MMF	1→4
		CBL-MTP12-4LC-OM4-3M	NA	QSFP+ ⁶	NA		3m	MMF	1→4
		CBL-MTP12-4LC-OM4-5M	NA	QSFP+ ⁶	NA		5m	MMF	1→4
		CBL-MTP12-4LC-OM4-7M	NA	QSFP+ ⁶	NA		7m	MMF	1→4
		CBL-MPO12-4LC-SM-5M	NA	QSFP+ ⁶	NA		5m	SMF	1→4

Notes

1. Optics come with attached MPO pigtail cables that are intended to plug into MPO Patch panels at customer site. Specified MPO cable length is different than the distance between two optics on both ends of the connection.
2. Wavelength varies for the optics. Different channels are supported on these optics and every channel provides different wavelength.
3. Follows the specification defined in the PSM4/CWDM4 MSAs.
4. XFP is an older technology and is mostly seen in legacy solutions only

5. For short distances, it is recommended that the user add appropriate value of in-line optical attenuation to avoid exceeding the receiver overload threshold (-1dBm for 10G-ER, and -7dBm for 10G-ZR)
6. Requires QSFP+ optics on one end and SFP+ optics on the other end, which are not included with the cables.
7. Requires QSFP+ optics on both ends, which are not included with the cables.
8. Requires mode conditioning cable.
9. Shipping soon.
10. Requires CXP optics on both ends, which are not included with the cables.

Frequently Asked Questions





<http://en.community.dell.com/techcenter/networking/w/wiki/11905.faq-optics-and-cables>

Optics and Cables Frequent Asked Questions Wiki

FAQ: Optics and cables

NETWORKING - WIKI

- What are the different types of cables?
- What is a lane?
- Can existing 10GbE fiber cables be used for 40GbE?
- Are DWDM and CWDM optics just like a regular optic?
- Is it ok to install a non-Dell optic in a Dell switch?
- Is it ok to install a non-Dell DAC cable in a Dell switch?
- Are Dell optics covered under Dell warranty and support options?
- Are Dell optics covered under the Lifetime Limited Warranty (LLW) for N series products?
- Is it ok to install an optic from a Dell switch into Dell server NICs?
- Is it ok to install an optic from a Dell switch into Dell storage?
- Are Dell approved optics covered under ProSupport, ProSupport Plus and ProSupport Flex for Data Center?
- Is it ok to install an optic from one Dell switch into another?
- Is it ok to use a Dell DAC cable to connect a Dell device to a non-Dell device?
- Is it ok to use a Dell DAC cable to connect Dell switch to other Dell devices?
- Is it ok to use a DAC cable between a 10GbE CNA and a 1GbE switch or 1GbE adapter with 10GbE switch?
- What is the difference between MPO and MTP connector?

Q. What are the different types of cables?

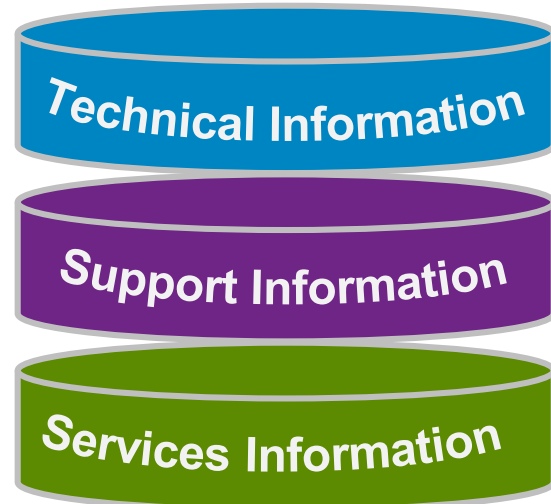
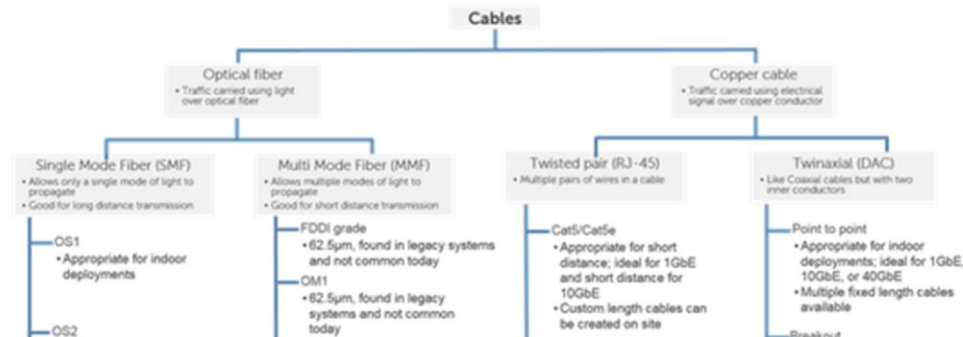

Deployment and Technical Guides





Deployment & Technical Guides

Detailed guides to help you get connected

Infrastructure

Product Focus	Document Title	Tags
Z9500	Dell Networking Cable Management Kit	Cable management, 40GbE
S6000, Z9500	Cable Breakout System for Dell Networking Fabric Switches	Patch panel, 40GbE



Feedback

We encourage readers of this publication to provide feedback on the quality and usefulness of this information by sending an email to

- [Saleem Muhammad](mailto:Saleem_Muhammad@dell.com) (Saleem_Muhammad@dell.com)

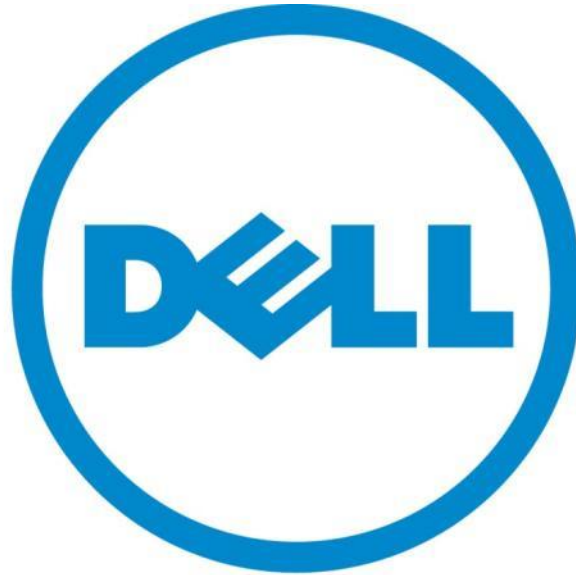

The power to do more